



Kason
by AKONA

FLUID BED DRYERS, COOLERS AND MOISTURIZERS

For bulk foods, pharmaceuticals, and chemicals
on a laboratory or production scale



Self-contained system with circular fluid bed processor

Greater performance in less space at lower cost than ever before possible

Kason by Akona fluid bed dryers, coolers, and moisturizers employ an innovative circular processing unit which is inherently stronger, lighter, and less costly to build—and finish to sanitary standards—than rectangular units having equivalent surface area.

Because the circular fluid bed processor is also more compact, complete fluid bed systems can be pre-engineered and pre-configured on caster-mounted frames, ready for installation and start up.

Moreover, Kason by Akona circular fluid bed processors maintain an unprecedented level of operating efficiency across a wide range of model sizes—from 18 to 84 in. (450 to 2125 mm) in diameter—for laboratory and pilot plant testing as well as batch or high-volume in-line drying, cooling, or moisturizing of bulk foods, pharmaceuticals, and chemicals.



This pilot-plant-scale drying system incorporates a surge bin, rotary valve, 24 in. (600 mm) diameter fluid bed processor, heater, blower, and controls on a caster-mounted frame. Processors as small as 18 in. (450 mm) in diameter are offered for laboratory applications.



With simple connections to an existing dust collector and power source, this fluid bed dryer system is ready to reduce the moisture content of boric acid from 10 to 0.5 percent on a batch basis. It combines a 40 in. (1000 mm) diameter fluid bed processor, heater, blower, and controller on a caster-mounted skid.



This skid-mounted, turnkey dryer-screener system configures a 48 in. (1225 mm) fluid bed dryer and two-deck circular vibratory screener in series to dry proprietary chemical powder while removing undersize and oversize particles at the rate of 2000 lbs/h (907 kg/h). The screener is equipped with a bulk bag hanger and extended discharge spout to align with the bag intake spout, and magnetic ferrule to remove tramp metal from the finished product prior to packaging.



Moisture content of bulk catalyst is reduced from 9 to 1 percent at a continuous rate of 2000 lbs/h (900 kg/h) with this self-contained drying system. It is comprised of a 48 in. (1225 mm) fluid bed processor, heater, blower, and cyclone separator, as well as a top-mounted Centri-Sift centrifugal sifter for continuous de-agglomerating of incoming material.

Circular fluid bed processor outperforms traditional rectangular configurations



Higher strength-to-weight ratio

Inherently rigid, a Kason by Akona circular fluid bed processor does not require heavy steel sidewalls or cross braces to withstand extensive vibration.

Smaller size range

Eight models range in diameter from 18 to 84 in. (450 to 2125 mm) offering efficient performance across a range of small to moderate volume applications not satisfied by rectangular units.

Akona offers free laboratory testing and/or rentals of fluid bed equipment for pilot plant testing

Akona's test laboratory is equipped with fluid bed dryers, coolers and moisturizers as well as screening, agglomerating and de-agglomerating equipment that are readily configured to simulate custom engineered systems integrated with your new or existing process.

Using customer-supplied material, Akona laboratory technicians,

Lower sanitary construction cost

A Kason by Akona circular fluid bed processor uses a lighter gauge shell and components, with fewer weld seams, and requires only one air inlet and outlet resulting in lower material and labor costs—especially when finished to food, dairy, or pharmaceutical standards.

Faster, easier set up

Compact and lightweight, a complete Kason circular fluid bed system can be frame-mounted with casters for low cost shipping, easy installation, and in-plant mobility.

applications engineers and visitors can verify system performance prior to equipment fabrication.

In addition, Kason by Akona can rent fluid bed equipment for pilot plant testing, enabling customers to engineer entire processes in which drying, cooling or moisturizing is an integral part.

Reduced engineering time

Kason by Akona self-contained fluid bed systems are lab tested using your material, engineered, and configured on a frame to ensure on-spec performance as delivered.

Faster, easier cleaning

With no internal cross members, fewer seams and corners, and a quick disconnect shell, a Kason by Akona circular fluid bed processor cuts cleaning time dramatically.



The Akona test laboratory controls and monitors all processing variables, optimizing equipment configurations according to each customer's materials and application parameters.

Principle of operation

Fluid bed processors dry, moisturize, heat, or cool bulk solid material by causing it to vibrate on a screen or perforated surface within a rising column of heated, chilled, or moisturized air.

Continuous air flow and vibration separate and fluidize individual particles, maximizing the surface area of material and, accordingly, the rate at which drying, moisturizing, heating or cooling can occur.

The vibratory motion of the processor also serves to convey the material along a defined pathway for uniform processing on a "first in/first out" basis, and to evacuate the fluid bed at the end of each cycle.

To prevent the uppermost layers of fluid bed particles from being pulled into the exhaust stream, the fluid bed exhaust plenum outward to a larger diameter than that of the fluid bed screen surface, reducing the air velocity. For drying, cooling or moisturizing applications that also requiring de-dusting of the material, exhaust plenums are cylindrical instead of tapered, causing dust to be drawn from the fluid bed chamber to a dust collection device. (Detail next page)

To fit your material application and integrate with existing plant equipment, Kason offers a comprehensive range of equipment available as components, sub-systems, or complete systems as described at bottom.

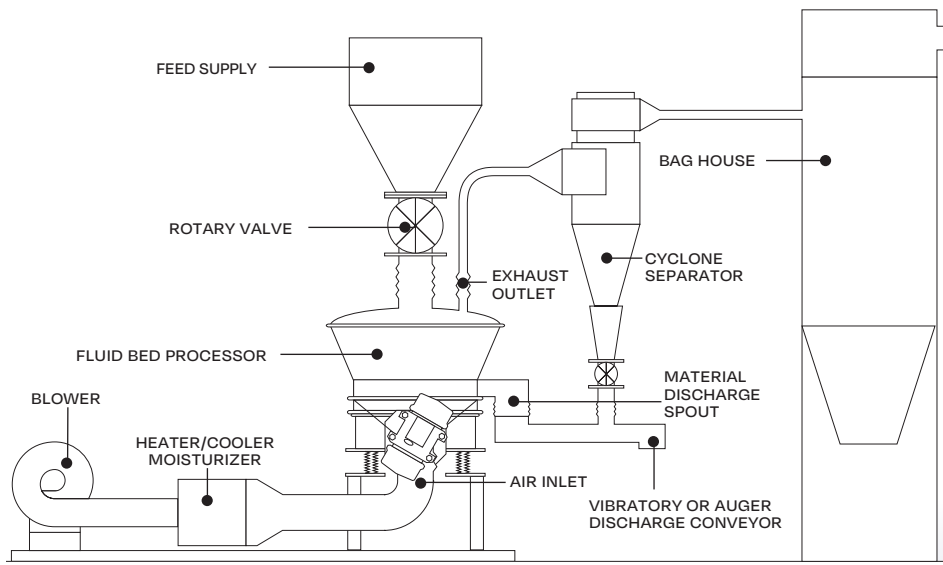

Supply side components:

- Centrifugal fans
- Air filters
- Electric heaters
- Oil- or gas-fired heaters
- Steam coils
- Water chillers/heat exchangers
- Humidifiers
- Ductwork and valves
- Air flow meters and automated controls

Fluid bed components:

- Storage bin with bin activator and rotary valve
- Vibratory or auger feeder (unnecessary when storage bin is positioned above fluid bed processor)
- Vibratory fluid bed processor including intake and exhaust plenums, flexible couplings, quick-disconnect cowl, circular screen, eccentric motor drives, and spring suspension
- Vibratory, auger, or pneumatic discharge conveyor
- Level sensors and automated controls

Exhaust-side components:

- Ductwork
- Cyclone separator with rotary valve
- Bag house with exhaust blower

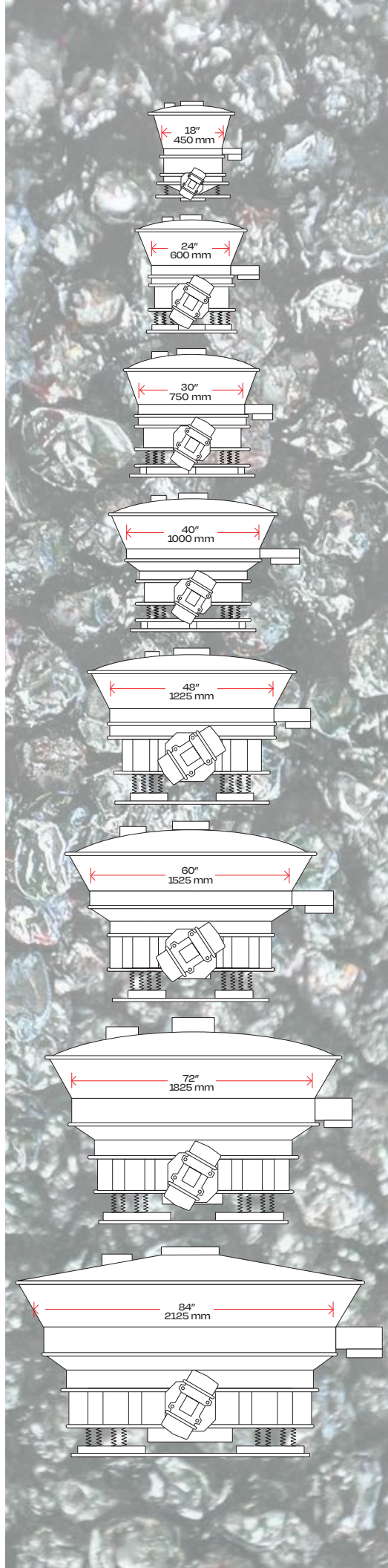

De-dust, scalp, de-agglomerate, or agglomerate while fluid bed processing

Configurations and accessories are available for scalping, de-dusting or de-agglomerating of materials while they are dried, cooled or moisturized, reducing or eliminating the initial and operating cost of separate equipment.

Kason by Akona Fluid Bed Processors are also effective at agglomerating of bulk materials independent of or in conjunction with, drying, cooling or moisturizing operations as described below.

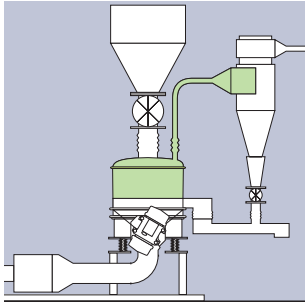

DE-DUSTING

For drying, cooling or moisturizing applications that also require de-dusting of the material, cylindrical exhaust plenums can be specified (instead of tapered plenums that reduce air speed), causing fluidized dust to be drawn from the fluid bed chamber into a cyclone or other dust collection device, eliminating the need for a separate de-dusting screener.

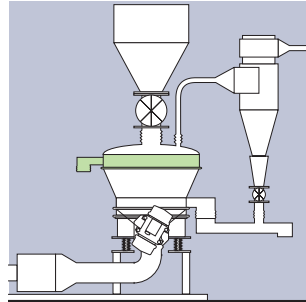

SCALPING

For scalping of oversize particles from material before it is dried, cooled or moisturized, the fluid bed chamber can be fitted with an integral, top-mounted screening deck that derives its vibratory motion from the fluidizing chamber's gyratory motors, significantly undercutting the initial and operating costs of a stand-alone screener, while preserving floor space.

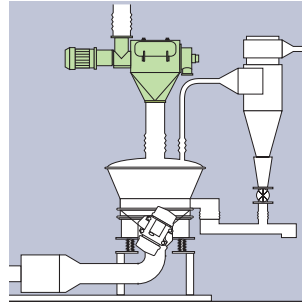

DE-AGGLOMERATING

Many materials that require fluid bed processing tend to form agglomerates that can reduce drying/cooling/moisturizing efficiency and/or uniformity of the finished product. In these instances, Kason fluid bed systems can be equipped with integral Centri-sifter centrifugal screeners for continuous de-agglomerating of incoming material. (Far left page, bottom right).

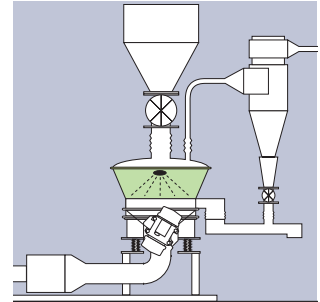

AGGLOMERATING

Kason by Akona Fluid Bed Agglomerators employ a spraying system within the fluid bed chamber that introduces moisture to powdered material as it is fluidized, causing particles to form agglomerates on a controlled basis. Fluid bed drying, cooling or moisturizing can be employed concurrently to condition the material, maximizing physical characteristics of the agglomerates as well as production efficiency.

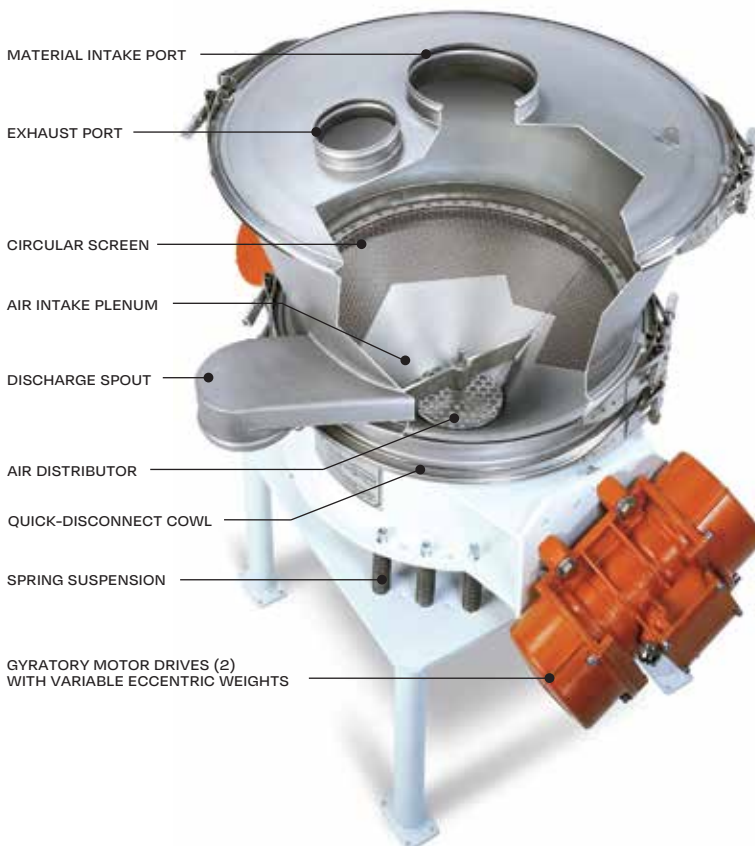

Standard equipment:

- Controls for inlet temperature, air velocity, bed depth, and retention time
- Quick-disconnect clamps for fast, thorough cleaning
- Choice of fluid bed air distributor
- High torque motor drive with double extension shaft and eccentric weight adjustment system to optimize vibratory motion for specific materials
- Continuous or batch operation
- 304 stainless steel contact surfaces
- Adjustable weir to control bed depth

Optional equipment:

- Construction to food, dairy or pharmaceutical standards
- Clean-in-place spray heads
- Explosion proof electricals
- 316 or higher stainless contact surfaces
- Cylindrical exhaust plenums for de-dusting
- Integral screening decks for scalping
- Integral centrifugal screeners for de-agglomerating
- Spraying systems for agglomerating



Vibroscreen Flo-Thru
Vibratory Screeners
with Air-Lift Device



Vibroscreen
Portable Batch Sifters



Vibroscreen
High-Capacity Classifiers



Vibroscreen Flo-Thru
Low-Profile, High-Capacity
Vibratory Screeners



Vibroscreen
Bag Dump Screening
Stations



Vibroscreen
Pneumati-Sifter
High-Capacity Screeners



Vibroscreen Pneumati-Sifter
Flo-Thru Ultra-
High-Capacity Screeners



Vibroscreen
Internal Recycle Cascade
Screening Decks



Centri-sifter Quick Clean
Centrifugal Sifters



Centri-sifter
Centrifugal Dewatering
Sifters



Centri-Sifter Pneumati -Sifter
Centrifugal Sifters



Centri-Sifter Quick-Clean
Miniature Sifters



Akona Process Solutions is the result of bringing together four well-established companies—Spiroflow, Kason, Cablevey, and Marion—each with a legacy of expertise in material handling and processing. With more than 200 years of combined experience, Akona provides comprehensive equipment solutions designed to meet the unique needs of its customers.

1609 Airport Rd, Monroe, NC 28110, United States
+1-877-463-1866

2397 IA-23, Oskaloosa, IA 52577, United States
+1-877-463-1866

3575 3rd Ave, Marion, IA 52302, United States
+1-877-463-1866

Unit B, Prime Point, Lower Eccleshill Rd, Darwen BB3
ORP
+01200422525

Otto-Hahn-Straße 11A, 61381 Friedrichsdorf,
Germany
+4969710405170

Cablevey

Kason

Marion

Spiroflow



akonasolutions.com